

AWWA C515-09
Resilient Seat
GATE VALVES

Model 2010FF-XH
(Formerly Model 2510)
ANSI 250/300 Flanged Ends, NRS

UNITED



Available:
Flange x Flange
(raised face)



MATERIAL LIST

DESCRIPTION	MATERIAL
Hex Bolt	304 Stn. Stl.
Washer	304 Stn. Stl.
Dirt Seal	EPDM
O-Ring (Bonnet Cap, Stem)	EPDM
O-Ring (Bonnet Cap, Bonnet)	EPDM
O-Ring (Stem)	EPDM
O-Ring (Bonnet to Body)	EPDM
Gate	EPDM Encapsulated DI
Operating Nut	Ductile Iron ASTM A536 65-45-12
Stem (2"~12")	AISI 420, 304, 316
Bonnet Cap	Ductile Iron ASTM A536 65-45-12
Split Ring (Stem)	Bronze C67400
Bonnet	Ductile Iron ASTM A536 65-45-12
Body	Ductile Iron ASTM A536 65-45-12
Bonnet Bolts	304 Stn. Stl.
Gate (Stem) Nut	Bronze C67400
Debris Cap	Plastic

Design and materials are subject to change without notice.

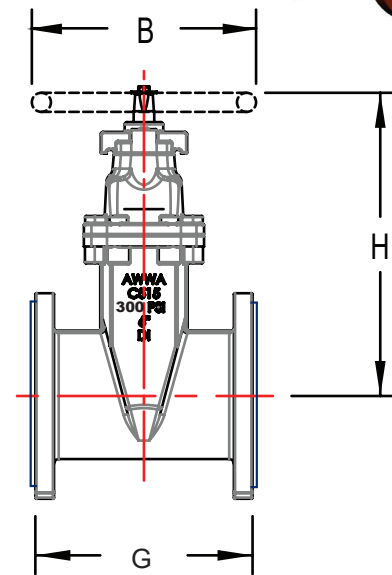
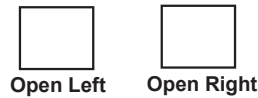

Description:

1. Conforms to AWWA C515-09.
2. Flange dimensions to ANSI B16.1 Class 250 / ANSI B16.5 Class 300.
3. Fusion Bond Epoxy Coated Interior and Exterior to AWWA C550 Standard. NSF-61 Certified.
4. 2" Square Operating Nut provided. Color coded black (open right valves provided with RED operating nuts).
5. Compatible with all industry standard Vertical Indicator Posts (NFPA 24).
6. Working Pressure:
UL/FM rated working pressure:
2-1/2"~12" - 300 psi, 14"~16" - 250 psi
Working Pressure: 18"~24" - 250 psi
7. Temperature: -23°C (-10°F) to 110°C (230°F)

DIMENSIONAL DATA

Size	Part No. (Flange x Flange)	G	H	B	Turns to Open
2"	2010FF-XH-120	7.0	9.5	7	6.5
2-1/2"	2010FF-XH-125	7.5	10.0	7	8.5
3"	2010FF-XH-130	8.0	11.0	10	10.5
4"	2010FF-XH-140	9.0	12.0	10	14
5"	2010FF-XH-150	10.0	15.	12	16
6"	2010FF-XH-160	10.5	16.4	12	20
8"	2010FF-XH-180	11.5	20.7	14	25.5
10"	2010FF-XH-200	13.0	24.4	16	31.8
12"	2010FF-XH-220	14.0	28.0	16	38
14"	2010FF-XH-240	15.0	32.9	22	45
16"	2010FF-XH-260	16.0	35.8	22	51
18"	2010FF-XH-280	17.0	41.0	24	57.5
20"	2010FF-XH-300	18.0	44.0	24	42
24"	2010FF-XH-340	20.0	50.79	24	50.8

Dimensions in inches



WARNING: This product can expose you to chemicals including lead, which is known to the State of California to cause cancer and birth defects or other reproductive harm. For more information go to www.P65Warnings.ca.gov.



United Water Products
5355 Ramona Blvd., Jacksonville, FL 32205
TEL. 877-766-4459 FAX: 877-766-4458
Website: www.unitedwaterproducts.com